

REV.	ECN NO.	DATE
00	新版发行	2013.9.16

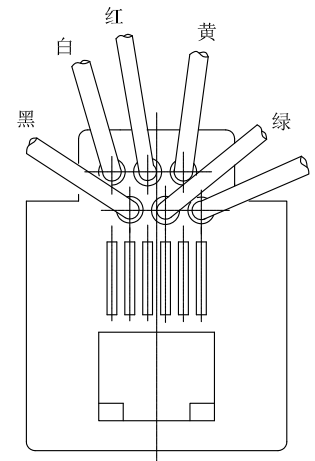
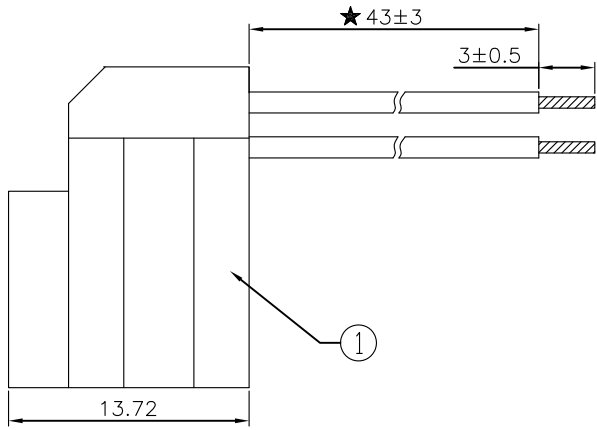
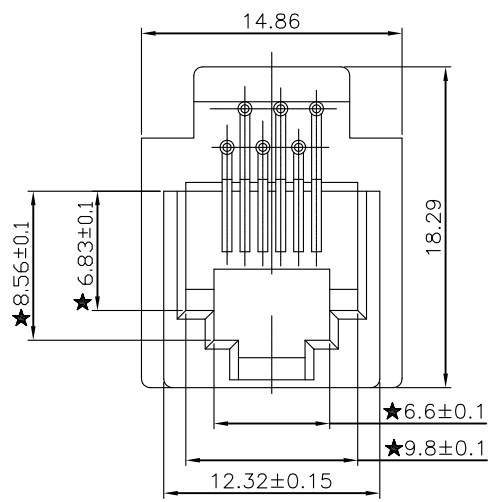

**SPECIFICATION NOTES:**

**ELECTRICAL:**

- VOLTAGE RATING: 125 VAC RMS
- CURRENT RATING: 1.5 AMP
- CONTACT RESISTANCE: 20mΩ MAX.
- INSULATION RESISTANCE: 1000MΩ MIN. AT 500V DC
- DIELECTRIC STRENGTH: 1000 V AC OR 1500V DC RMS AT 0.5mA 50 Hz / 60 Hz FOR 1 MINUTE

**MECHANICAL:**

- HOUSING: ABS UL94V-2 COLOR GRAY B8018
- CONTACT MATERIAL: DIA. PHOSPHORBRONZE  
φ=0.46MM
- PLATING: GOLD PLATING AT CONTACT AREA, NICKEL 30U MIN. OVER ALL
- OPERATING LIFE: 750 CYCLES MIN.
- MATING/UNMATING FORCE: 30N/3.06KG MAX.
- RETENTION STRENGTH: 50N MIN. FOR 60S±5S

**ENVIRONMENTAL:**

- STORAGE: 0°C TO +70°C RELATIVE HUMIDITY < 80%
- GUARANTEE PERIOD: 6 MONTHS
- OPERATION: 0°C TO +70°C
- SALT WATER SPRAY: 8H

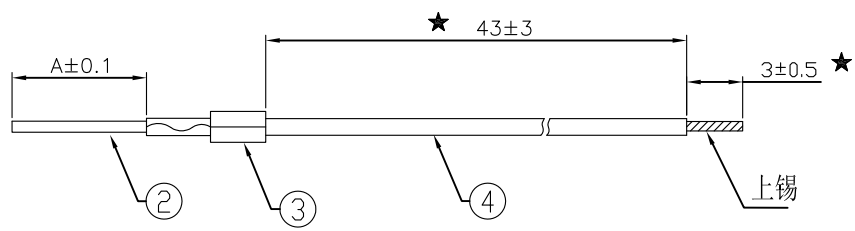

**机构特性:**

- 塑壳材质: 普通ABS浅灰(环保料)B8018
- 圆针材质: 磷青铜, φ0.46MM
- 圆针电镀: 全区先镀镍底30U MIN., 后依订单决定镀金厚度, 如表说明
- 可靠性: 最少750次插拔
- 插入/拔出力: 30N/3.06KG MAX.
- 配合强度: 50N 60S±5S.

**电气特性**

- 额定电压: 125 VAC RMS
- 额定电流: 1.5 AMP
- 接触电阻: 20mΩ MAX
- 绝缘电阻: 1000 MΩ MIN. @ 500 VDC
- 耐压强度: 1000 V AC 或 1500V DC RMS @ 0.5mA 50 Hz 或 60 Hz 一分钟

**环境特性**

- 储存温度: 0°C TO +70°C 相对湿度 < 80%
- 储存时间: 6个月
- 工作温度: 0°C TO +70°C
- 盐雾测试时间: 8H

4	H04-A089	电子线	UL1061 26AWG 电子线
3	1G910-G010	正端	黄铜
2	E001-JGF-011	金丝	磷铜表面镀镍后镀金G/F(黄红白A=11.2兰绿黑A=9.7)
1	21102B00528	623K 塑壳 6P6C (UL)	普通ABS浅灰(环保料)B8018
NO.	PART NO.	NAME	DESCRIPTION

RoHS COMPLIANT

**Coorle Technology**

第三视角 A4 SIZE SCALE 1:1 UNIT mm CUSTOMER: N/A MODEL NO: N/A

**TOLERANCES**

0~15 ±0.15  
15~30 ±0.20  
30~50 ±0.25  
50~ ±0.30  
ANGLES: ±1°

Material:	SEE TABLE	Designed:	沙吉邓 2013.9.16	NAME:	623K带线插座 6P6C GF 蓝黄绿红黑白 6L=43 不含剥头3 刻UL
Finish:	SEE TABLE	Checked:		DWG NO.	CL3L0524
SHEET	1 OF 1	Approved:		PART NO.	
					REV. 版本
					00